

SPEED INCREASER GEARBOX FOR PUMPS GR.2 WITH EUROPEAN UNIFIED FLANGE

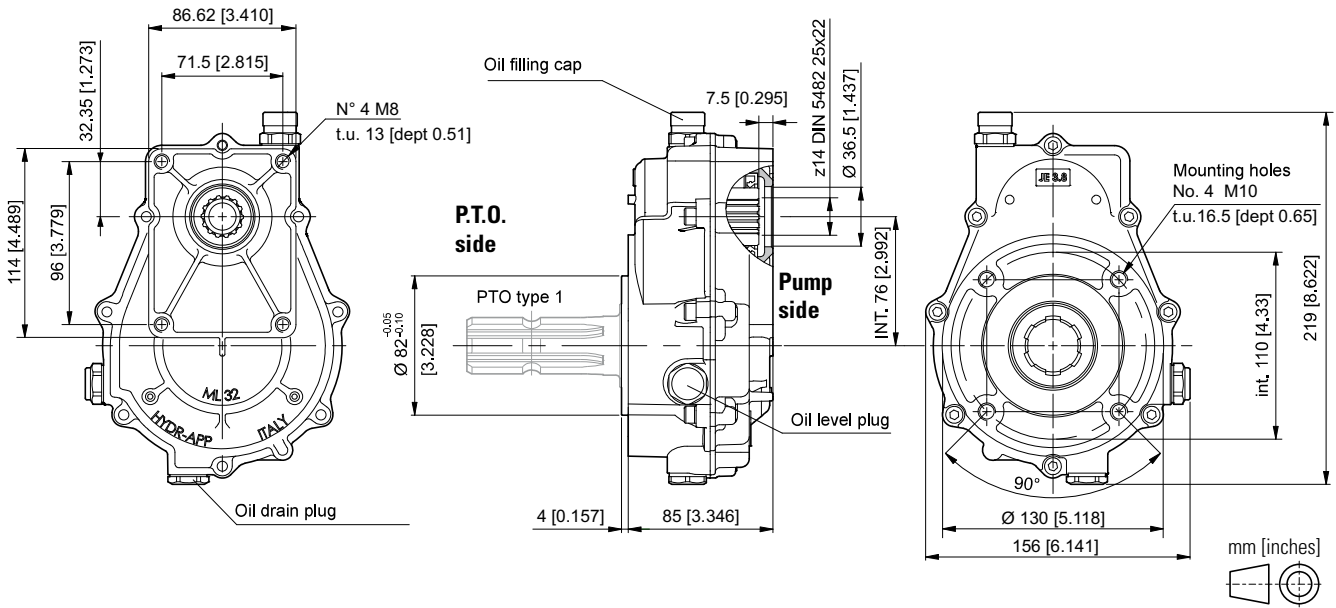

P.T.O.

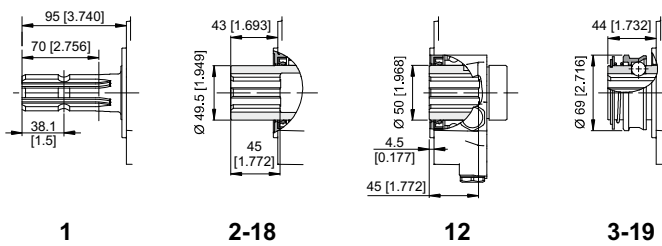

Mounting positions

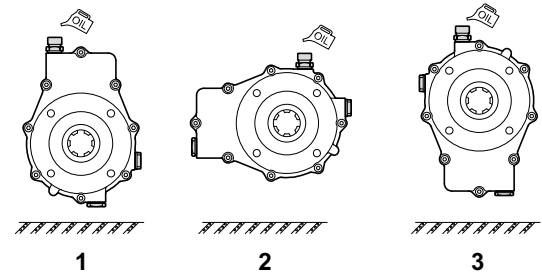

ORDERING CODE

ML32 - ** -1/ *** - *

ML32 = Speed increaser (aluminium body)

P.T.O.

- 1** = Male 1" 3/8 DIN 9611
- 2** = Female 1" 3/8 DIN 9611
- 3** = Female 1" 3/8 DIN 9611 + tightening
- 12** = Female 1" 3/8 DIN 9611 short
- 18** = Female z21 - 16/32 DIN 9611
- 19** = Female z21 - 16/32 DIN 9611 + tightening

Mounting positions
1 / 2 / 3

Transmission ratio

- 1,5** = 1 : 1,5
- 2** = 1 : 2,0
- 2,5** = 1 : 2,5
- 3** = 1 : 3,0
- 3,5** = 1 : 3,5
- 3,8** = 1 : 3,8

Coupling for pump to be required to our sales department.

TECHNICAL DATA

Transmission ratio	Maximum torque Nm [lbf-ft]				Weight kg [lb]
	540 rpm		1000 rpm		
	C1*	C2*	C1*	C2*	
1 : 1.5	190 [140.1]	127 [93.7]	183 [135]	122 [90]	4,3 [9.5]
1 : 2.0	170 [125.4]	85 [62.7]	156 [115.1]	78 [57.5]	4,3 [9.5]
1 : 2.5	178 [131.3]	71 [52.4]	163 [120.2]	65 [47.9]	4,2 [9.3]
1 : 3.0	201 [148.2]	67 [49.4]	—	—	4,1 [9]
1 : 3.5	213 [157.1]	61 [45]	—	—	4 [8.8]
1 : 3.8	182 [134.2]	47 [34.7]	—	—	4 [8.8]

* Maximum torque on pump:
C1= maximum starting torque; C2= maximum torque for continuous duty.

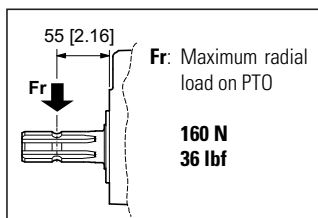
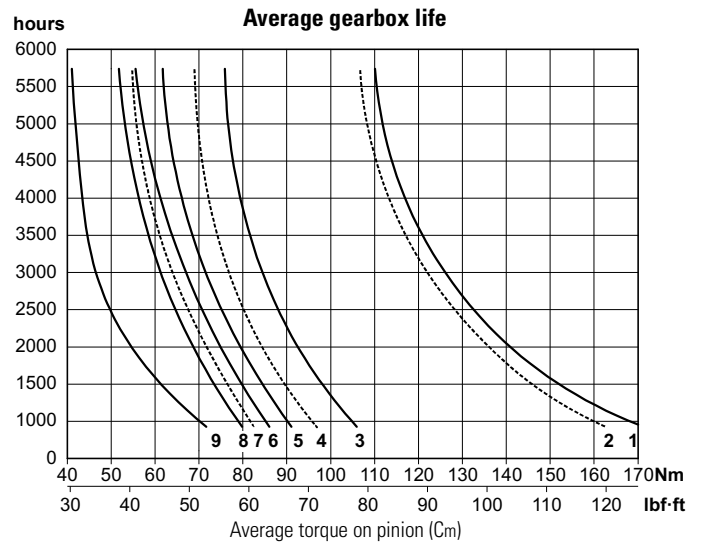

Mounting positions	Oil liters [US gallon]
1	0.15 [0.04]
2	0.11 [0.03]
3	0.09 [0.02]

Input rpm	Output (transmission ratio)					
	1 : 1.5	1 : 2.0	1 : 2.5	1 : 3.0	1 : 3.5	1 : 3.8
540	curve	1	3	5	6	8
	rpm	810	1080	1350	1680	1836
1000	curve	2	4	7	—	—
	rpm	1500	2000	2500	—	—

SPARE PARTS

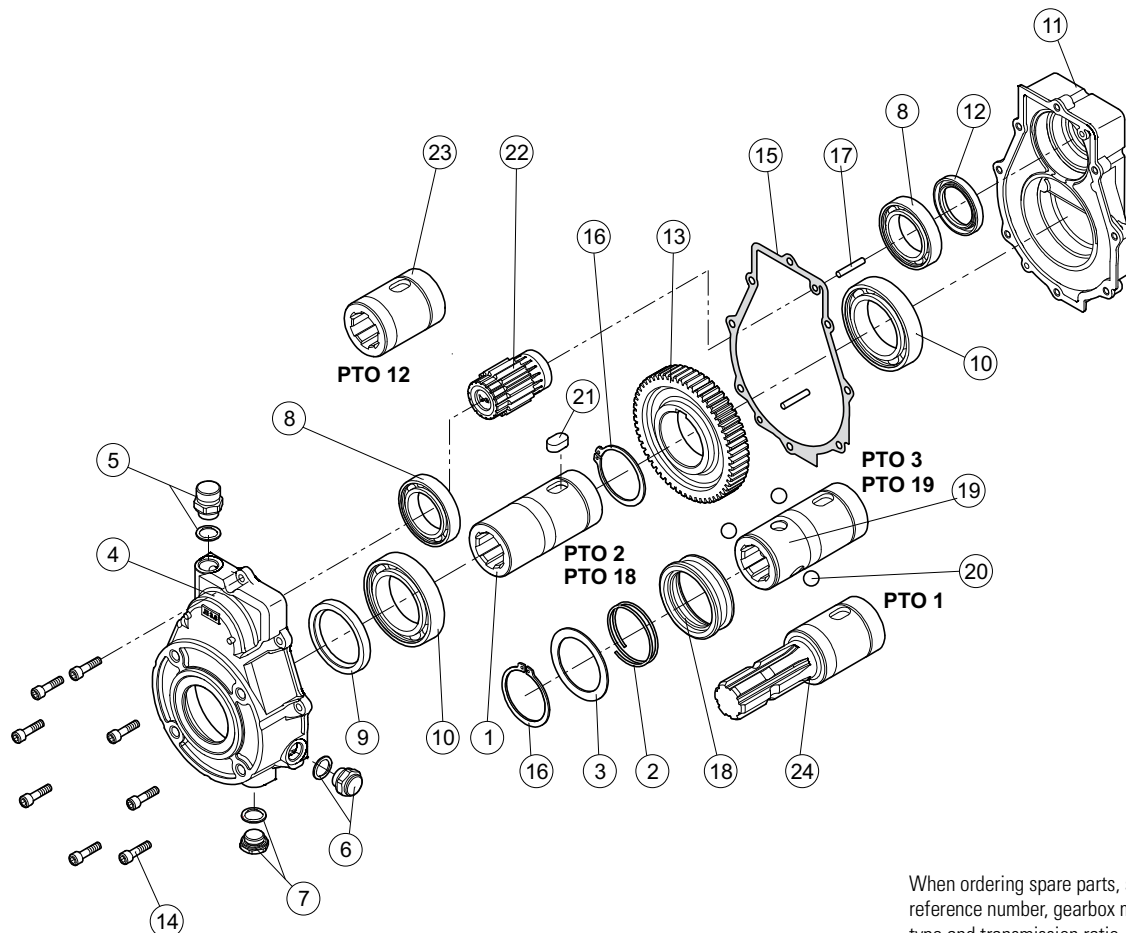

When ordering spare parts, specify reference number, gearbox model, PTO type and transmission ratio.